

SH50

Specifications

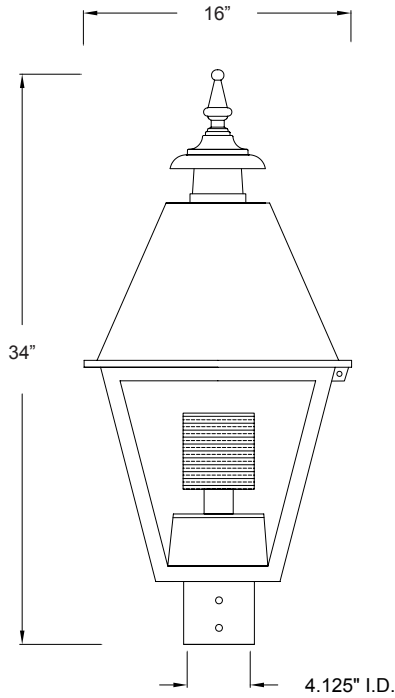

The SH50 series square luminaire shall consist of a roof assembly, cage, diffuser, capital, ballast assembly and an internal optical system. The hinged roof shall be made of cast aluminum and shall have a spun aluminum cupola and a cast aluminum finial. The diffuser shall be either clear, frosted or white acrylic or polycarbonate or clear tempered glass. The cage shall be made of cast aluminum and shall be welded to the capital. All castings shall be formed true to pattern, with no warping or mold shifting.

The electrical and optical components shall be mounted on a cast aluminum ballast plate within the capital. The medium or mogul porcelain socket shall be 4kV pulse rated. The HID ballast shall be HPF, CWA, multi-tap, supplied with capacitor and ignitor. Luminaire shall be ETL certified as suitable for wet locations. **Lamps by others.**

LEDs shall be Cree X-Lamp XP-L White, with sealed LediL Strada optics. Class II driver shall be 50,000+ hours rated.

The optical assembly shall be mechanically secured to the ballast plate and/or the roof, as appropriate.

The luminaire shall mount to a 3"OD or 4"OD x 3"H tenon with three sets of two stainless steel tamper resistant screws. All exposed metal parts shall receive baked-on smooth semi-gloss powder coat finish. Ships boxed and palletized.

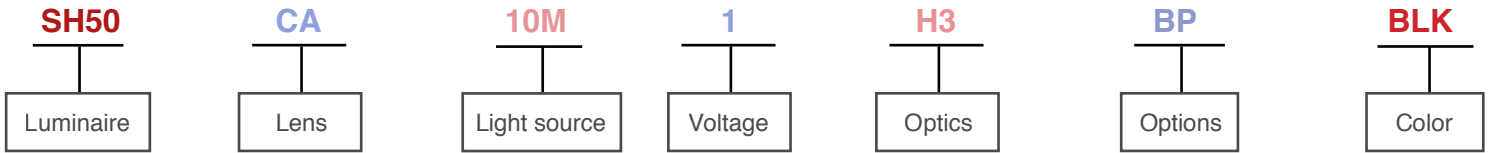

CA clear acrylic
FA frosted acrylic
CP clear polycarbonate
FP frosted polycarbonate
WP sign white polycarbonate
TG tempered glass

5M 50MH
7M 70MH
10M 100MH
15M 150MH
25M 250MH

5H 50HPS
7H 70HPS
10H 100HPS
15H 150HPS
25H 250HPS

5L4K 50W LED
 4000K, 5660 lm
8L4K 82W LED
 4000K, 9287 lm

1 120V
2 208V
3 240V
4 277V
5 347V
6 480V
U 120-277V

BA - bare lamp
R5 - glass refractor IES V
R3 - glass refractor IES III
CO - dual optical cone IES V
HR3 - rooftop reflector, horizontal lamp, IES III

LV - louver stack IES V
II IES II (LED)
IV IES IV (LED)
V IES V (LED)

HS - house side shield
SF - single fuse
DF - double fuse
BP - button photocell
LP - locking photocell
GC - glass chimney
FN - no finial
FA finial "A"

FB finial "B"

FC finial "C"

BLK black
BRZ bronze
GRN green
GRY grey
WHT white
CTM custom



Suggested pole and bracket combinations

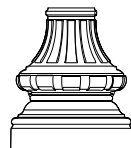

SP01

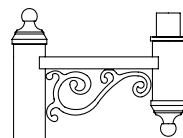

SA01-A



We see what moves you.