

Weight: 8 lbs

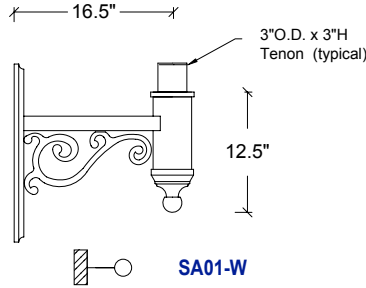

SA01-W

SA01

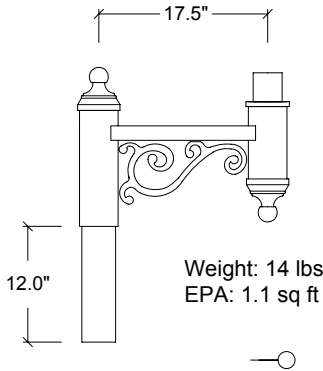

Weight: 14 lbs  
EPA: 1.1 sq ft

SA01-A

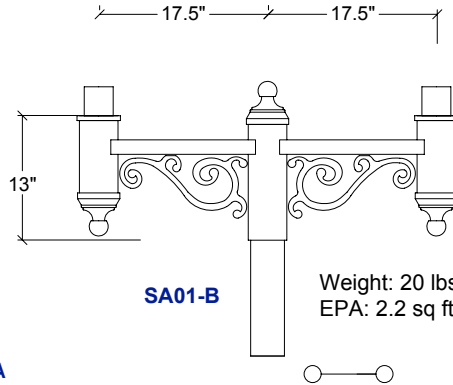

Weight: 20 lbs  
EPA: 2.2 sq ft

SA01-B

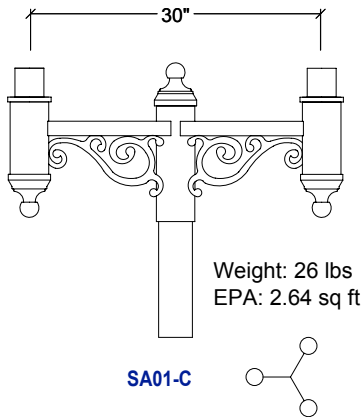

Weight: 26 lbs  
EPA: 2.64 sq ft

SA01-C

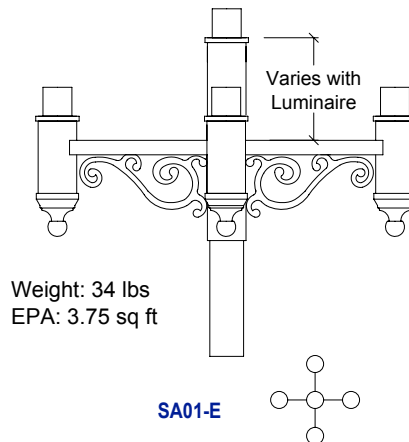

Weight: 34 lbs  
EPA: 3.75 sq ft

SA01-E

**ADDITIONAL CONFIGURATIONS AVAILABLE**

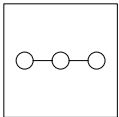

SA01-BC

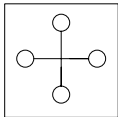

SA01-D

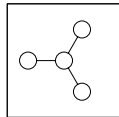

SA01-CC

The arm shall be SA01 \_\_\_\_\_ (specify configuration), consisting of an ornamental cast aluminum scroll welded to a round central column. Wall brackets shall be made of aluminum rectangle with a cast aluminum scroll all welded to the cast aluminum wall plate.

The rectangular 3"x1-1/2"x 1/8" thick arm shall be welded to the ornamental cast scroll. The central 4"OD column shall be made of extruded non-fluted aluminum. All hardware shall be tamper resistant, stainless steel.

A variety of configurations is available, some of which are illustrated below. Those not illustrated are noted in the bottom left-hand corner. Non-standard configurations may be feasible, please consult factory for details.

Post top arms shall be equipped with a 12"L x 3-1/2" OD round pole tenon. Arms shall be equipped with 3" (76mm) diameter tenons for fixture mounting. Post top arms are not pre-wired and shall be wired by the contractor. Wall brackets shall be pre-wired, with a 12" slack for ease of wiring to source on the wall side and for wiring with wire nuts on the fixture side. Mounting hardware for wall brackets is not included.

**SA01**

Arm	Layout	Color
-----	--------	-------

- W** - wall bracket
- A** - single at 90°
- B** - twin at 180°
- BC** - twin at 180° plus central
- C** - triple at 120°
- CC** - triple at 120° plus central
- D** - quad at 90°
- E** - quad at 90° plus central

- BLK** - black
- GRN** - green
- BRZ** - bronze
- GRY** - grey
- WHT** - white
- CTM** - custom

**Suggested pole and luminaire combinations**

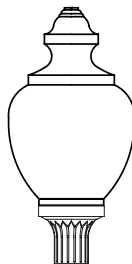

SH01



SP01

**Sheridan**  
lighting systems, inc.